



GREMAC

Mobile Drum Screens



Electric drive, available with petrol or diesel generator set (optional)

Electronic load-sensing control for a continuous workflow

Galvanised hopper, 2,300 mm wide with a drop-off height of only 1,910 mm

Trailer with a maximum weight of 3,500 kg

Strong electric-gearred motors

Powerful and with a 3 meter drum unique in its class of up to 3.5 tons



No loss of material due to a one-piece fines discharge conveyor

Frame and all structural parts are galvanised steel for a long machine life

Crank support winches for secure positioning

Control panel optionally available with remote control unit

Easy to change screen mats

Up to 75 m³/h screening capacity



GREMAC

Mobile Drum Screens



GREMAC e2+

Whether excavated soil, stones, rubble or other screenable materials, the GREMAC e2+ masters all tasks with ease and unrivalled performance.

This is achieved through its 3 meter drum - unique in its class!

Options include remote control, separator grid and exchangeable screen mats. Added to the basic configuration, these make the e2+ a true allrounder and high performer in the 3.5-ton class.

Simple, robust, versatile – the GREMAC e2+

Up to 75 m³/h screening capacity

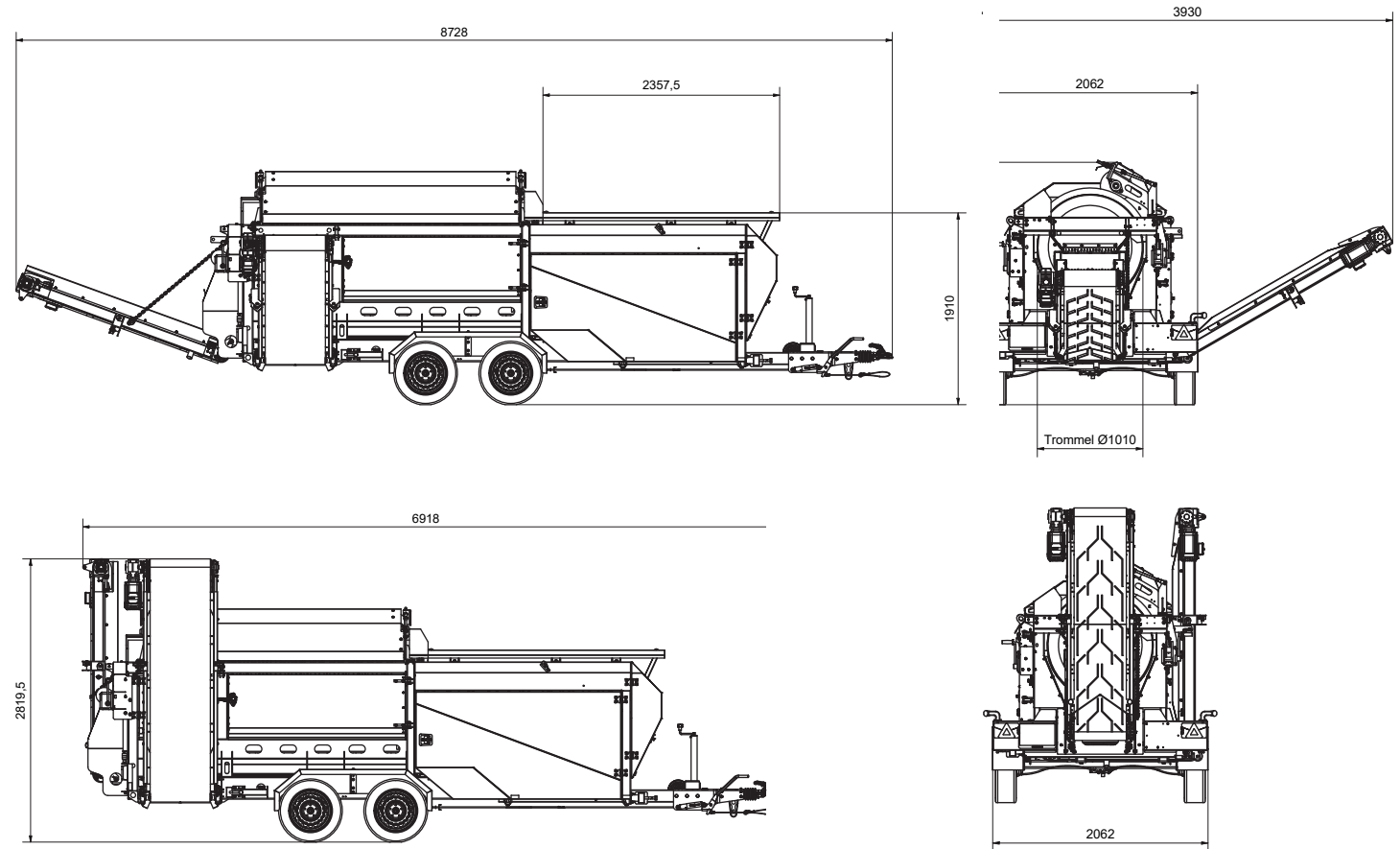

Contact

GREMAC OHG
 Twiestweg 5
 26209 Hatten | Germany
 Tel.: +49 (0)4482 9 74 01 00
 info@gremac.de

www.gremac.de

Technical Data

Drum length: 3,000 mm
Diameter: 1,000 mm
Screening surface: 9.3 m²
Mesh size: 2 - 80 mm
Drive: Electric (optionally available with petrol or diesel generator)

Hopper: 1.3 m³
Weight: 3.250 kg - max. 3.500 kg
Towing device: Ball head, towing eyelet (40/50 mm)
Supply voltage: 380 - 420 V / CEE-16A

Robust, galvanised & Made in Germany

#screeningmadesimple